



Multi-Use Poly Bin

CECOR's Multi-Use Poly Bin is ideal for in-plant and interplant bulk handling and shipping of industrial materials and preprocessed food products. This linear low density polyethylene (LLDPE) plastic container weighs less, costs less and is easy to clean. Molded pallet base features optional two-way or four-way entry for easy moving by fork truck.



PA-328 Multi-Use Poly Bin

- **Durable light weight polyethylene.**
- **Smooth, rounded, non-stick surfaces ... for easy cleaning.**
- **Nestable when empty - stackable bins save space.**
- **Molded-in pallet base with two-way or optional four-way fork lift entry.**
- **Standard color - gray. Other colors available. Natural color is USDA and FDA approved for food processing.**
- **Withstands temperatures from -20° to 150°F.**

Poly Bin

Model OA-P28

Bin Dimensions	40-1/2" long x 40-1/2" wide x 29" deep
Overall Dimensions	44" long x 44" wide x 34" deep
Volume	28 cubic feet
Load Rating	2000 lbs
Under-clearance	5"
Weight	90 lbs.

Poly Stacking Lid Model LID-P28

Save space by stacking bins. Medium duty Poly Stacking Lid



PA-328 - Poly Bin

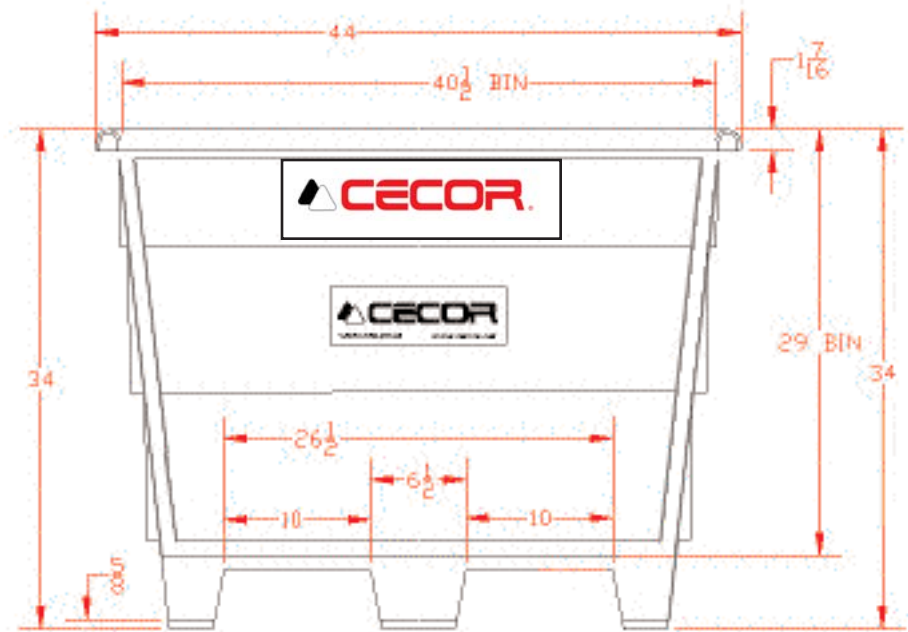

PL-328H - Poly Stacking Lid

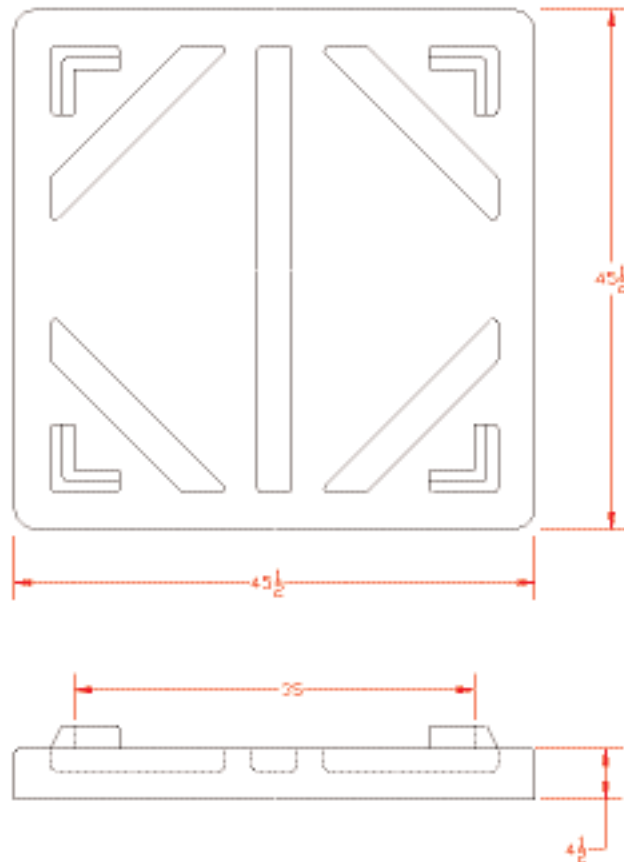

NOTE: Engineering specifications subject to change without notice.